

## CE Series



### About the product

The CE, HD2, and HD2A Series embossed panel doors are designed to meet the architectural requirements for embossed panel doors. The door construction combines the features and benefits of polystyrene core laminated construction. Refer Architectural section for specifications and the selection and usage guide of the appropriate door constructions.

This premium door construction combines the strength and dimensional stability of steel with the structural integrity of the laminate core. The continuous bonding of core to steel face sheets provides an attractive, flat door, free of face welding marks.

To meet application, specification and performance requirements, the CE Series embossed panel doors offers a wide range of specifiable options including sizes, glass light designs and hardware (mechanical, pneumatic, electrical) preparations.

CE Series doors are 1 3/4" (45 mm) thick.

### Installation

1. Installation shall conform to the published Steelcraft installation instructions, ANSI A250.11-2012 (formerly SDI 105) *Recommended Erection Instructions for Steel Frames and HMMMA 840*.
2. Fire Rated Assemblies must be in accordance with NFPA Pamphlet 80. The Authority Having Jurisdiction is the final authority on issues related to the installation and use of installed Fire Rated Doors.

### Features and benefits

Steelcraft's CE Series embossed panel doors offer the following standard unique features, which enhance long term performance and durability:

1. **A-40 Galvanized steel** face sheets
2. **Polystyrene Core** provides enhanced thermal performance
3. **Full Height, Epoxy Filled Mechanical Interlock Edges** provide structural support and stability the full height of the door edges. Available edge options:
  - **Visible Edge Seam (standard):** full height, epoxy filled mechanical Interlocked edges
  - **Filled Edge Seam (optional add to standard):** seam filled with structural adhesive and dressed smooth. Includes tack welds above and below edge cutouts for hinges, locks, etc.
4. **Universal Hinge Preparations** (patented) allow for easy field conversion from standard weight .134" (3.3 mm) hinges to heavy weight .180" (4.7 mm) hinges.
5. **14 Gauge [0.067" (1.7 mm)] Inverted Top and Bottom Channels** provide stability and protection for the top and bottom edges from abuse.
6. **Beveled Hinge and Lock Edges** allow for tighter installation tolerances, ensure easier operation and eliminate binding and sticking.
7. **Recessed Dezigner™ Glass Trim** provides a clean, neat and flush finish with the door surface.
8. **Factory Applied Baked-On Rust Inhibiting Primer** paint in accordance with ANSI A250.10-2011.

### Specification compliance

1. Door construction for Steelcraft CE Series embossed panel doors meets the requirements of ANSI A250.8-2014 (SDI 100).
2. Hardware preparations and reinforcements are in accordance with ANSI A250.6-2003 (R2009). Locations are in accordance with ANSI/DHI A115 unless otherwise stated.
3. Door construction for the CE Series embossed panel doors meets ANSI A117.1-1998 (ADA) requirements for minimum 10" (254 mm) bottom rail height measured from the floor.

### Fire ratings

CE Series embossed panel doors meet the broadest fire rating requirements. They are listed for installations requiring compliance to both neutral pressure testing (ASTM E152 and UL-10B) and positive pressure standards (UL-10C).

**Laminated core**

**Standard CE Series Core**

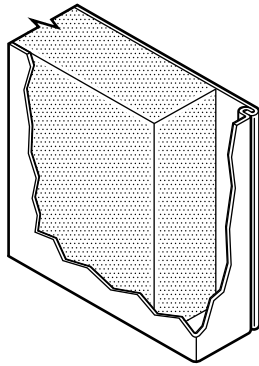

- 1 pound (453.6g) per ft<sup>3</sup> density polystyrene slab
- Laminated to both face sheets with contact adhesive
- Assembled door is run through high pressure pinch rollers, achieving ultimate bond

**Standard Premium Edge Construction**

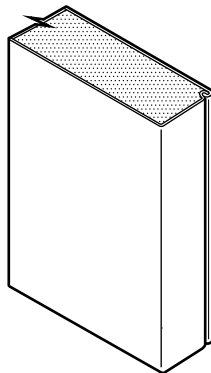

- Beveled hinge & lock edges
- Full height mechanical interlock with epoxy adhesive
- Visible edge seam standard
- Seamless edge optional

**Standard Rigid 14 Gauge End Channel Construction**

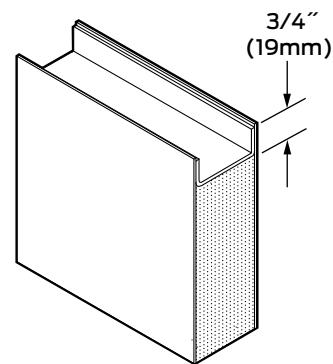

- 14 gauge inverted galvanized top & bottom channels
- Projection welded to both face sheets
- For optional caps, see [""Weather seals" on page 145.](#)

Door application and usage			
Series	Steel Thickness	Opening	Usage Frequency
CE20	20 Ga (0.8 mm)	Interior or Exterior - Galvanized Steel	Standard Duty Light Commercial applications with minimal use and abuse
CE18, HD18, HD2A18	18 Ga (1.0 mm)		Heavy Duty Heavy Commercial & Institutional applications with high use
CE16, HD16, HD2A16	16 Ga (1.3 mm)		Extra Heavy Duty Extra Heavy Commercial applications with potential of very high use

**Standard hardware preparations**

Typical hardware applications shown. Refer to "Hardware" section for more details.

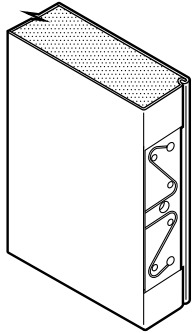

**Universal Mortise Hinge Prep**  
7 Gauge Universal hinge reinforcement

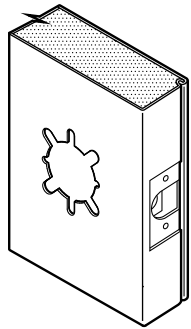

**61L Lock**

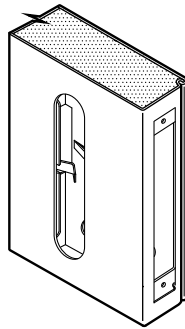

**86 Lock**

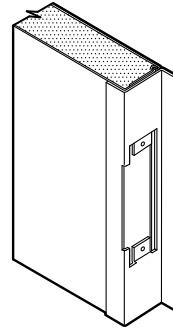

**Inactive Leaf ASA Strike Prep with Astragal attached**

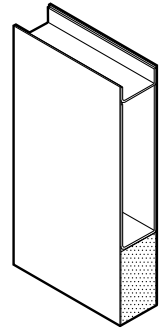

**Optional 14 Gauge Closer Reinforcement**

**Standard: mortised and reinforced for**

- Patented Universal hinge preparations allow for easy field conversion from standard 4 1/2" x .134" standard weight hinges to 4 1/2" (114 mm) x .180" heavy weight hinges. Optional hinge preparation for 5" x .146" standard weight hinges or for 5" (127 mm) x .190" heavy weight hinges is also available.
- The cylindrical 161, 61L and mortise 86 lock preps are the most commonly used active leaf preparations. The 4 7/8 (124 mm) strike prep is the most commonly used inactive leaf preparation
- Optional reinforcements for surface Closers are available.
- Special hardware applications are available.

**Door Sizes and ANSI A250.8 Conversions**

Steelcraft product selection for CE Series doors has been matched to ANSI/ISD Level and Model designations.

- In accordance with ANSI A250.8-2014 (SDI 100), core material is not specific to the level or model designations. Core material selection is specified based on preference and application.
- Recommended minimum frame gauge also applies to the frequency of operation of the opening.

Series	ANSI A250.8 - SDI 100			Edge Construction	Edge Maximum Sizes			
	Level	Model	Description		6 Panel Door Design		8 Panel Door Design	
					Single	Pair	Single	Pair
<b>Level 1: Light Commercial</b>								
CE20	1	1	Full Flush	Visible	3'0" x 8'0"	6'0" x 8'0"	3'0" x 7'0"	6'0" x 7'0"
CE20		2	Seamless	Filled	914 mm x 2438 mm	1829 mm x 2438 mm	914 mm x 2134 mm	1829 mm x 2134 mm
<b>Level 2: Heavy Duty Commercial &amp; Institutional</b>								
CE18	2	1	Full Flush	Visible	3'8" x 7'0"	7'4" x 7'0"	Not Available	Not Available
HD218		2	Seamless	Filled				
HD2A18								
<b>Level 3: Extra Heavy Duty Commercial &amp; Institutional</b>								
CE16	3	1	Full Flush	Visible	3'0" x 8'0"	6'0" x 8'0"	Not Available	Not Available
HD216					914 mm x 2438 mm	1829 mm x 2438 mm		
HD2A16		2	Seamless	Filled	3'8" x 7'0"	7'4" x 7'0"		
					1118 mm x 2134 mm	2235 mm x 2134 mm		

**Door edge construction**

- Optional Edge Seams available in the CE Series doors:
  - CF:** the mechanical edge seam is dressed smooth and finished prior to applying the factory primer.

**Beveled Edge with Full Height Mechanical Interlock**

**Standard Visible Edge Seam**

**CE Series Visible Seam Features**

- Full height mechanical interlock
- Interlock filled with epoxy adhesive
- Visible edge seam

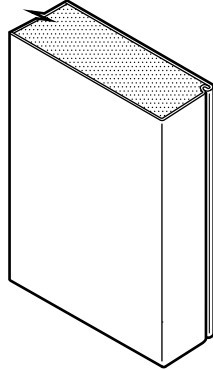

**Optional Seamless Edge**

**CF Series Seam Filled Features**

- Standard Visible Edge Seam is tack welded above and below edge cutouts for hinges, locks, etc.
- Edge Seam is then filled with structural adhesive and dressed smooth
- No visible edge seam

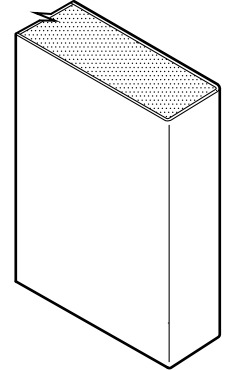

**Embossed Pattern Designs**

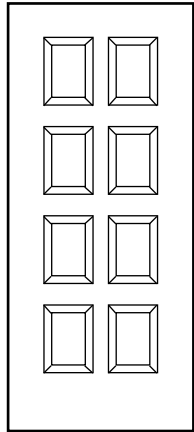

8 Panel

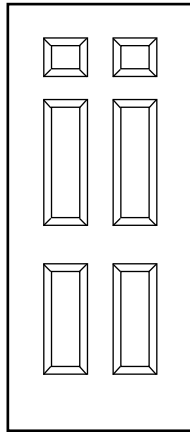

6 Panel

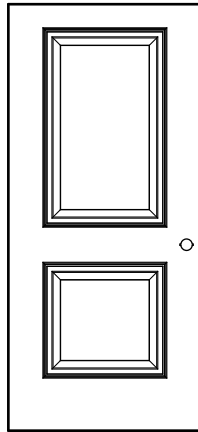

HD2

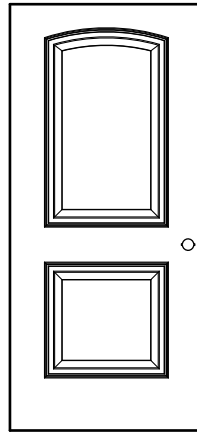

HD2A

**Notes:**

- Standard door sizes are available.
- Refer to pages 120-124 of this manual for all panel dimensions.
- Availability of non standard door sizes is limited.

**Glass light options**

(Refer to the Lights and Louvers section for further details and options)

**Designer® Trim**

- Standard for 1/4" Thick Glass
- Optional for 1/2" Thick Glass

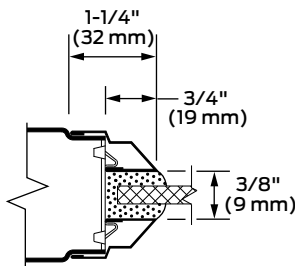

**Flush Mounted Steel Trim**

- For 1" Thick Glass

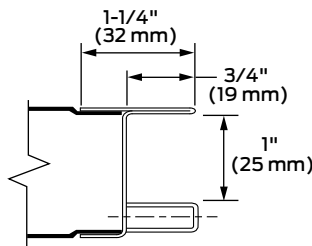

Divider Muntins are Not Available

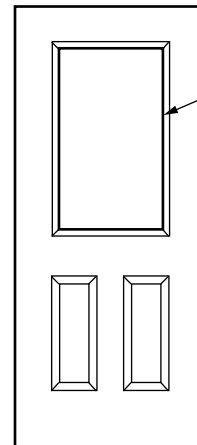

**Note:** Glazing type and thickness vary per job requirements.