

Installation Instructions

# CL5000

CL5210 Mortise Latch



**CODELOCKS**  
control + convenience

# CONTENTS

Check the contents of the box are correct according to the model.

**This box should also contain an Installation Template and Programming and Operating Instructions.**

## Box Contents

- 1 Front Plate
- 2 Back Plate
- 3 Lever Handles
- 4 Gasket x 2
- 5 Sprung Spindle
- 6 Fire Cup
- 7 1.5v AA Batteries (x4)
- 8 Mortise Latch, Strike and 4 Screws
- 9 Fixing Bolts x 4 (Inc. spare)
- 10 Cable Tube and Ring Nut and Cap
- 11 Alignment Insert
- 12 Latch Support Post
- 13 Allen Keys
- 14 Cable Connections for REM1 and REM2
- 15 Front Plate Cylinder Keys
- 16 Front Plate Cylinder Cover
- 17 Classroom Function Tailpiece

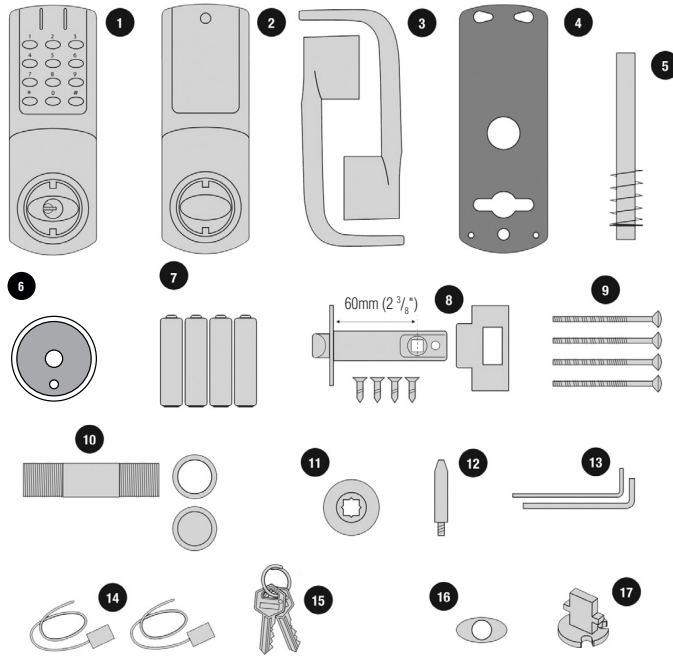

## Tools Required

- Philips Screwdriver
- Power Drill
- Drill Bits:
  - 10mm (3/8")
  - 25mm (1")
  - 54mm (2 1/8")
- Pliers (for cutting bolts)
- Chisel 25mm (1")
- Hammer / Mallet
- Stanley Knife
- Adhesive Tape, Pencil, Brawdawl, Tape Measure

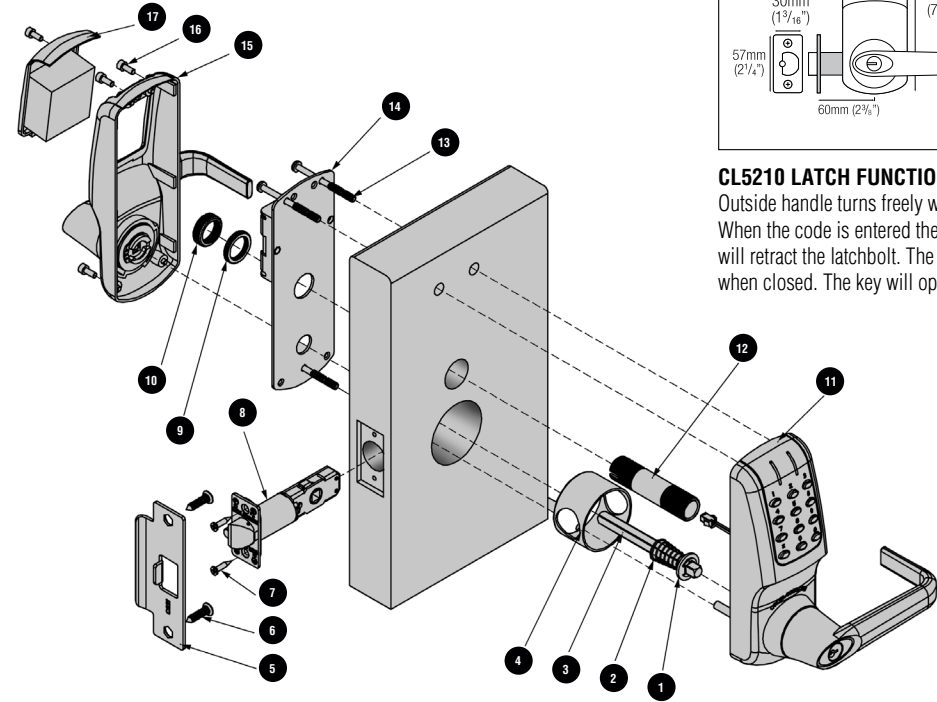

- |                   |                          |                     |
|-------------------|--------------------------|---------------------|
| 1 Washer          | 7 Countersunk Head Screw | 13 Fixing Bolts x 3 |
| 2 Spindle Spring  | 8 Latch                  | 14 Inside Plate     |
| 3 Spindle         | 9 Ring Nut               | 15 Back Plate       |
| 4 Fire Cup        | 10 Threaded Tube Cap     | 16 Fixing Bolts x 4 |
| 5 'T' Type Strike | 11 Front Plate           | 17 Battery Cover    |
| 6 Screw           | 12 Threaded Cable Tube   |                     |

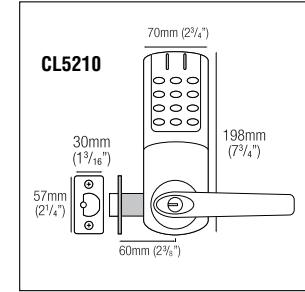

## CL5210 LATCH FUNCTION

Outside handle turns freely without operating the latchbolt. When the code is entered the Blue LED flashes, and the handle will retract the latchbolt. The latch automatically locks the door when closed. The key will open the door without the code.

## OPERATIONS CHECK

You should familiarise yourself with the operation of the lock and check that all parts work properly.

Remove the battery cover from the back plate and install the 4 x AA cells supplied.

Connect the cables from the front plate and back plate. A BEEP should be heard when you do this. If no BEEP is heard then check that the batteries are correctly installed.

Place the long spindle in the front plate socket and using finger grip only, test that the spindle is easily moved 80° in both directions. Leave socket in the centred position.

Enter the factory Master Code #1234.

The Blue LED should flash and the spindle should not turn as before. After 5 seconds the Red LED should flash and the spindle should turn easily again. This confirms that the clutch engaged correctly when the code was entered.

**N.B.** When the Master Code is entered 3 times consecutively without performing a programming function, a penalty time of 10 seconds is activated.

Disconnect the cables.

## SPECIAL FIXING NOTE

### REMOTE RELEASE OPTION

Cables are provided for the **REM 1** and **REM 2** terminals on the circuit board (Fig 1).

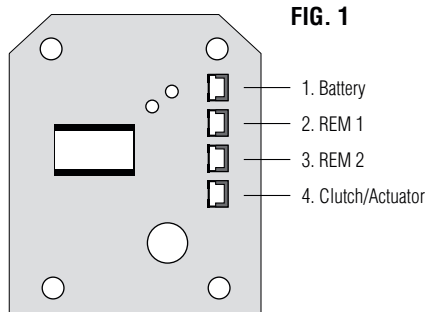

**REM 1** is for connection to a reception desk push button or a door intercom system. Pressing the button will cause the Blue LED to flash on the lock and release the lock for the pre-set time.

**REM 2** is for connection to the building alarm system to release a door in an emergency. This allows rooms, wards, offices to be easily checked to ensure that no person is trapped or overlooked during an emergency evacuation. When activated **REM 2** will maintain the unlocked condition for 30 minutes, the Red LED will flash and BEEP during this time.

The lock will automatically lock again after 30 minutes. If necessary Program 11 can be used to re-lock before the end of the 30 minutes.

**REM 1** and **REM 2** do not require additional power. They are normally open contacts requiring a momentary or maintained signal to close.

## CL5210 INSTALLATION

### Take time to be precise and finish the job quicker.

Installation holes must be drilled in exactly the correct positions and precisely at right angles to the door surface. Lock components must be vertically and horizontally accurate in relation to each other and to the door.

### WEDGE THE DOOR FIRMLY TO PREVENT MOVEMENT WHILST DRILLING AND CHISELING.

- 1 Lightly mark a height line on the edge and both faces of the door and on the door jamb, to indicate the top of the lock when fitted. Crease the template along one of the dotted lines (60mm (2<sup>3</sup>/<sub>8</sub>" ) or 70mm (2<sup>3</sup>/<sub>4</sub>" ) latch) and tape it to the door with the top in line with the height line. Mark the holes to be drilled. Mark the centre line of latch on to the door edge.

Apply the template to the other side of the door precisely against the height line and the centre line of latch mark. Mark the holes to be drilled again. (See diagram A).

- 2 Keeping the drill level and straight, drill a 25mm (1") hole in the centre of the door edge to accept the latch. Put the latch into the hole and holding it square to the door edge, draw around the faceplate. Starting with the top and bottom cuts, chisel a rebate to allow the latch faceplate to fit flush with the door edge. Remove the latch.
- 3 Keeping the drill level and straight, drill the holes in the door face. Drill from both sides of the door to increase accuracy and to avoid damage to the other side when a drill goes right through.
- 4 Insert the fire cup into the 54mm (2<sup>1</sup>/<sub>8</sub>" ) hole. **N.B.** Open the side of the fire cup to face code side with small bolt through hole at the bottom.

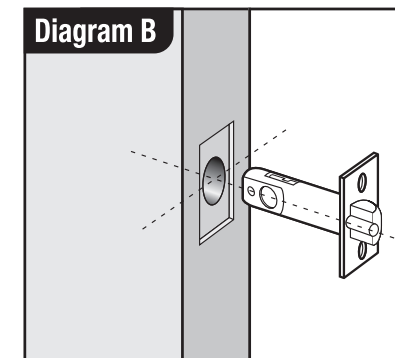
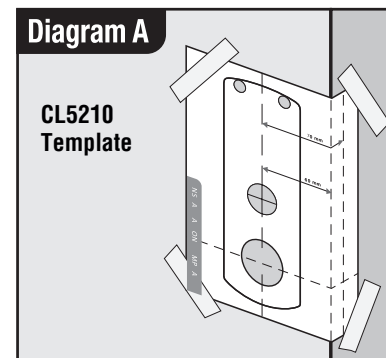

Continued overleaf

- 5 Reinsert the latch and fix the screws, with the bevel towards the door frame. (See diagram B).
- 6 Fit the latch support post on the inside of the front plate, in outer hole Side A for a left hand hung door and in outer hole B for a right hand hung door. (See diagram C below).

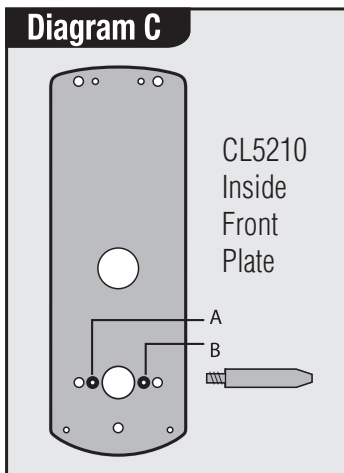

- 7 Screw the cable tube into the front plate, passing the cable through the tube. For doors less than 45mm ( $1\frac{3}{4}$ " ) thick, screw the tube all the way to the end of the thread. For doors more than 45mm ( $1\frac{3}{4}$ " ) leave an appropriate amount of thread showing to accommodate ring nut. Example: For a 60mm ( $2\frac{3}{8}$ " ) thick door, leave 15mm ( $\frac{3}{5}$ " ) of thread showing.
- 8 Fit the self-adhesive gaskets to the front and back plates. The gaskets provide friction against the door so that it is not necessary to over-tighten the fixing bolts to provide stability.

- 9 Remove the 4 socket head bolts from the back plate (2 are found under the battery cover). This will release the inside fixing plate.
- 10 Cut the fixing bolts to correct length. Measured from beneath the bolt head, the length should be the door thickness, plus approximately 15mm ( $\frac{3}{5}$ " ) to the nearest cutting point of the bolt. **N.B.** Always cut the bolts at one of the cutting points so as not to damage a thread. Use the cutting edges of pliers to crimp strongly several times around the selected cutting point. The surplus end should break off quite easily.

- 11 Put the spindle into the latch with the spring on the front plate side of the door.
- 12 Apply the front plate over the spindle, passing the cable tube through the door and the latch support post through the latch. Place the fixing plate over the cable tube and spindle. Screw the ring nut onto the cable tube until finger tight. Fit the alignment insert over the spindle. Screw the fixing bolts through to the front plate. (See diagram D, page 7).
- 13 Check that the spindle turns freely, and the latch retracts and projects smoothly, with the alignment insert in place. If it is tight, loosen the fixing bolts slightly and adjust the position of the fixing plate until the spindle will turn freely. Tighten the fixing bolts. Test the spindle again. Do not over-tighten the bolts as this may cause the door to distort and affect the lock function.

#### REMOVE THE ALIGNMENT INSERT.

- 14 Connect the cables, storing any excess cable within the door. Screw end cap onto cable tube. Then install the batteries.

- 15 Fit the back plate over the fixing plate using the 4 socket head screws.
- 16 Fit the cylinder cover and outside handle to the front plate.
- 17 Fit the inside handle to the back plate.
- 18 The inside handle will now retract the latchbolt. The outside handle will turn freely without retracting the latch. Enter the factory Master Code #1234. The Blue LED will flash and the outside handle will now retract the latch.

#### 19 FITTING THE STRIKE PLATE

Position the strike plate on the door frame so that the aperture lines up with the flat of the latchbolt, and NOT the plunger. Mark the positions of the fixing screws and draw around the aperture of the strike plate. Chisel out the aperture to 15mm ( $\frac{3}{5}$ " ) deep to receive the latchbolt. Fix the strike plate to the surface of the frame using only the top fixing screw. Gently close the door and check that the latchbolt enters the aperture easily, and is held without too much 'play'. When satisfied, draw around the outline of the strike plate, remove it and cut a rebate to enable the strike plate to lie flush with the surface. Re-fix the strike plate using both screws.

**N.B.** The plunger beside the latchbolt deadlocks it to protect against manipulation or 'shimming'. The strike plate must be accurately installed so that the plunger CANNOT enter the aperture when the door is closed, even when it is slammed shut.

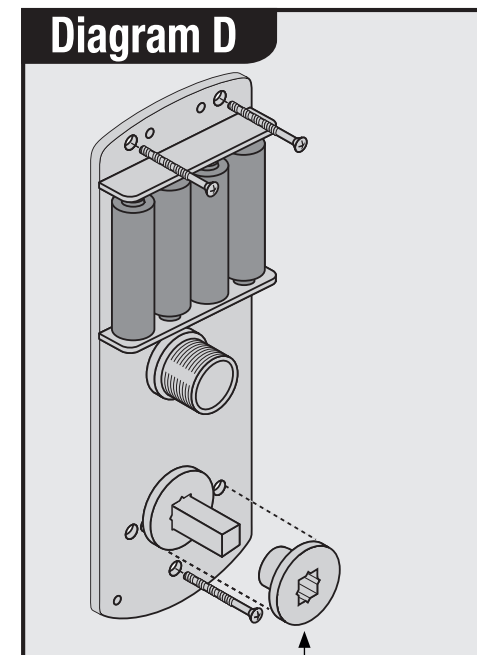

**Alignment insert MUST be removed before completing installation.**



## CODELOCKS UK HEADQUARTERS

Tel: +44 (0) 1635 239645  
Fax: +44 (0) 1635 239644  
sales@codelocks.co.uk  
www.codelocks.co.uk

Helpline, service & spares  
Freephone: 0800 393 405

## CODELOCKS INC US

Tel: +1 714 979 2900  
Fax: +1 714 979 2902  
sales@codelocks.us  
www.codelocks.us

Helpline, service & spares  
Toll free: 1.877.codelock

## CODELOCKS

### (Australia) PTY LTD

Tel: +61 2 9882 1009  
Fax: +61 2 9882 6030  
sales@codelocks.com.au  
www.codelocks.com.au

Helpline, service & spares  
Toll free: 1800 052 131



# CODELOCKS

control + convenience

www.codelocks.com

