

VERY IMPORTANT-PLEASE NOTE!

THE ENCLOSED RECTANGULAR PLATE CANNOT BE USED WITH OUR VERTICAL ROD PANIC MODEL VR531 SINCE THE HOLES WILL NOT MATCH UP.

IF YOU WANT TO USE THIS RECTANGULAR PLATE WITH OUR VERTICAL ROD MODEL VR531, PLEASE SPECIFY A SPECIAL PLATE THAT WE STOCK WHICH MATCHES THE HOLE POSITIONS FOR VR531. THIS IS PLATE #PEDBPVR

FOLD AND ALIGN ALONG HIGH EDGE OF DOOR

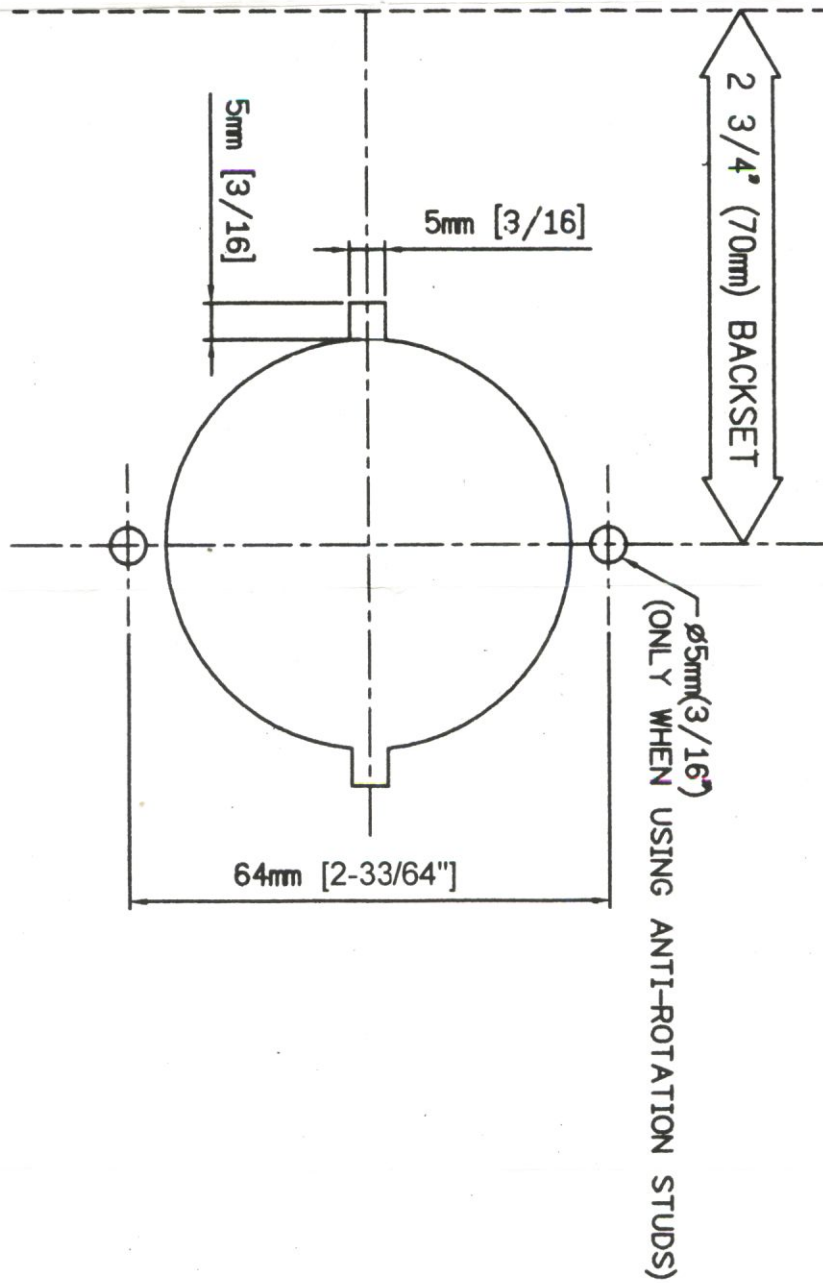

MOUNTING INSTRUCTIONS FOR **LHL500/BKL500**

VERY IMPORTANT

PLEASE NOTE THE FOLLOWING IMPORTANT INSTRUCTIONS.

IF, AFTER YOU HAVE INSTALLED AN LHL500/BKL500 SERIES LOCK WITH VARIOUS BRANDS OF RIM EXIT DEVICES AND IF YOU FIND, WHEN ROTATING LEVER OR KNOB, THAT YOU DO NOT HAVE FULL LATCH BOLT RETRACTION, REMOVE THE LOCK FROM THE DOOR AND BEND THE TAIL PIECE ENOUGH TO COMPENSATE FOR THE AMOUNT OF EXTRA DEGREES NEEDED TO CREATE FULL LATCH BOLT RETRACTION WITH THE PANIC DEVICE YOU ARE USING.

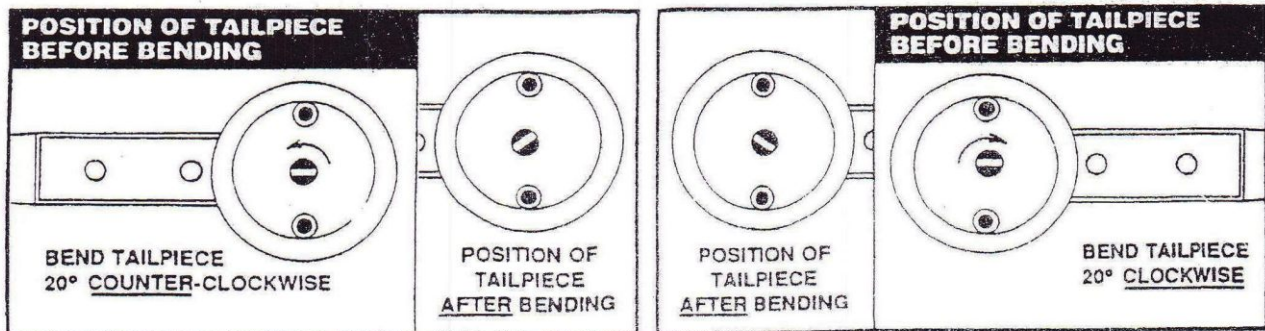

HOW TO USE AND INSTALL OUR THRU BOLT MOUNTING STUDS AND/OR OUR DELUXE MOUNTING PLATE WITH EXIT DEVICE ED500 SERIES.

Please note that it is important that you always consider using mounting studs on any lever operated locking device because of the extra torquing pressure created.

Without the use of mounting studs or the deluxe mounting plate with thru sex bolts, the lever lock may rotate when over torqued in the locked position.

It is simple to install this lever locking device with either the thru bolts or deluxe mounting plate with sex bolts. Just follow these instructions.

WHEN USING LOCK WITH TWO MOUNTING STUDS:

Firstly, note that we have re-engineered all of our ball and lever locks in a way that they now automatically contain two small cast spurs at the 3:00 and 9:00 o'clock position.

These two small spurs will interface with the small cutouts in most hollow steel doors prepped for a cylindrical lock. (A 2 1/8" diameter hole in face of the door)

These two small spurs will substantially reduce the risk of the lock rotating when torqued in the locked position.

In addition, we have supplied two mounting studs which are used at the 12:00 and 6:00 o'clock positions. To install them, follow the instructions outlined below.

NOTE: THIS LOCK IS NON-HANDED WHEN USED WITH OUR EXIT DEVICE ED500 SERIES. TO MAKE LOCK HANDED WITH OTHER EXIT DEVICES, USE HANDING PLATE ENCLOSED AND FOLLOW INSTRUCTIONS ON PAGE 4.

THRUBOLT INSTALLATION WITH ED500 SERIES (TO USE WITH VR500 SERIES ORDER MOUNTING PLATE WITHOUT SEX BOLT HOLES)

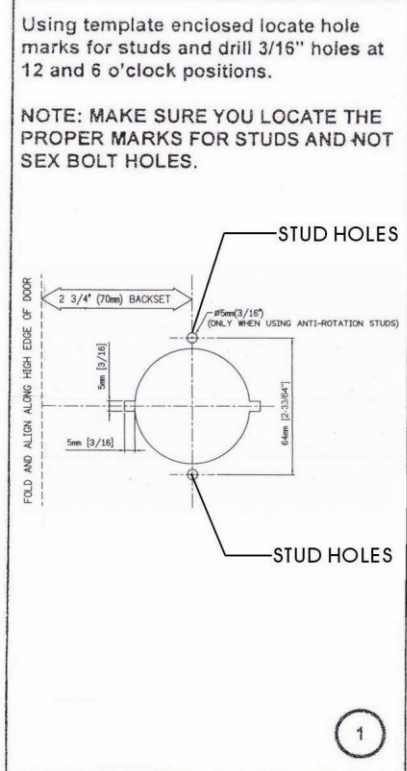
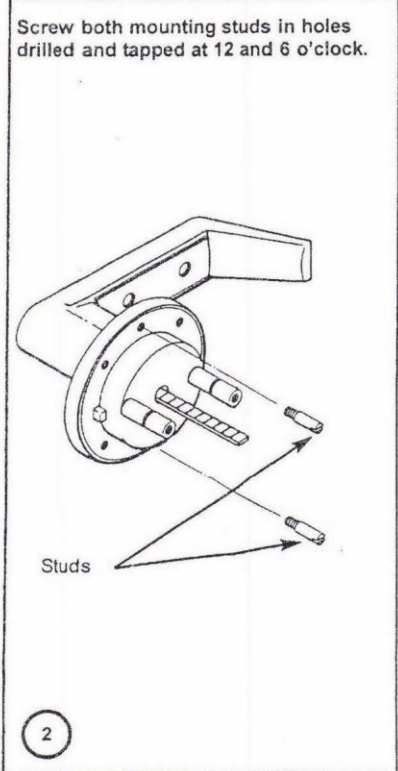
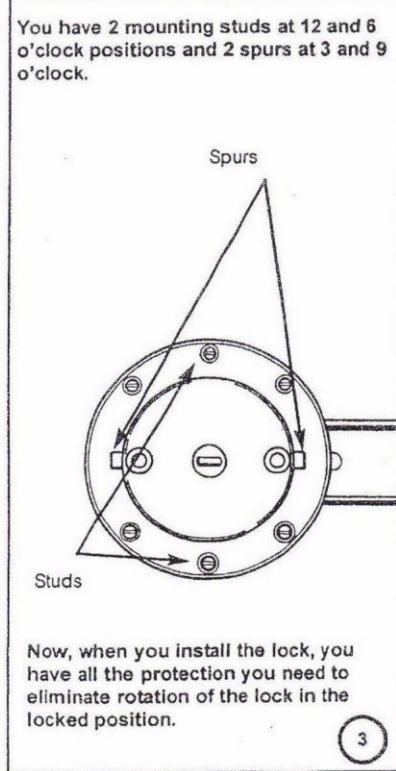
<p>Using template enclosed locate hole marks for studs and drill 3/16" holes at 12 and 6 o'clock positions.</p> <p>NOTE: MAKE SURE YOU LOCATE THE PROPER MARKS FOR STUDS AND NOT SEX BOLT HOLES.</p>  <p style="text-align: right;">1</p>	<p>Screw both mounting studs in holes drilled and tapped at 12 and 6 o'clock.</p>  <p style="text-align: right;">2</p>	<p>You have 2 mounting studs at 12 and 6 o'clock positions and 2 spurs at 3 and 9 o'clock.</p>  <p>Now, when you install the lock, you have all the protection you need to eliminate rotation of the lock in the locked position.</p> <p style="text-align: right;">3</p>
------------------------------------------------------------------------------------------------------------------------------------------------------------------------------------------------------------------------------------------------------------------------------------------------------------------------------------	-----------------------------------------------------------------------------------------------------------------------------------------------------------------------------------------------------------	---------------------------------------------------------------------------------------------------------------------------------------------------------------------------------------------------------------------------------------------------------------------------------------------------------------------------------------------------------------

How to Install Our Deluxe Mounting Plate with the Two Thru Sex Bolts:

Take the mounting plate, and attach it as shown below to the back of the lever lock with the use of four small set screws supplied. Be sure that you position the mounting plate correctly so that it will interface with the position needed for attaching of the lever lock and mounting plate to our ED500 series exit device with the use of the two sex bolts supplied.

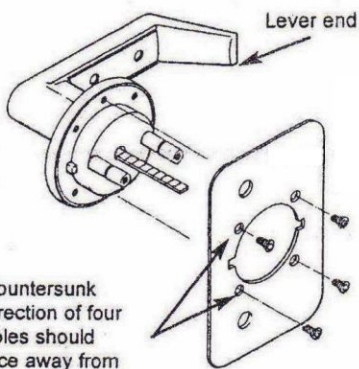

1

Also, be sure that you mount the plate to the lever lock so that the countersunk direction of holes face away from the lock. Otherwise, the small mounting machine screws for the mounting plate will protrude above the surface of the mounting plate and will not sit flush with door surface.

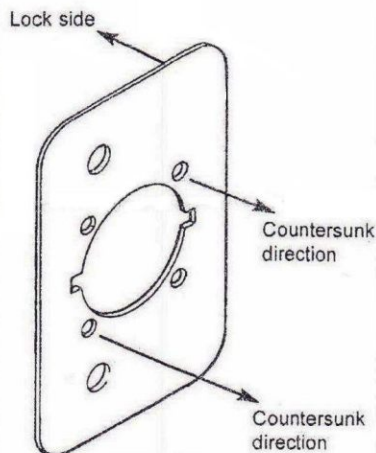

2

After you have properly attached the mounting plate to the lever lock, with the use of the template supplied, drill your holes for the sex bolts supplied.

NOTE: MAKE SURE YOU LOCATE THE PROPER MARKS FOR SEX BOLT AND NOT STUD HOLES.

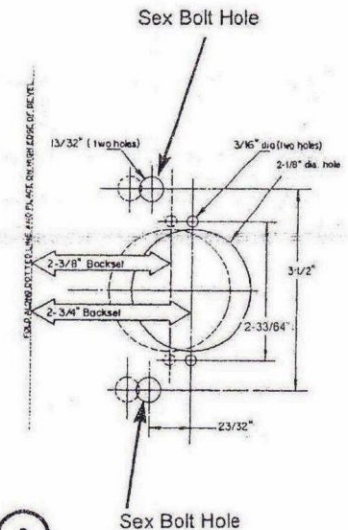

3

Install the exit device and attach it to the lever lock and mounting plate with the use of the two thru sex bolts.

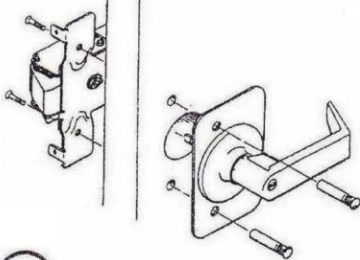

4

This installation is excellent. The lever lock cannot rotate in the locked position.

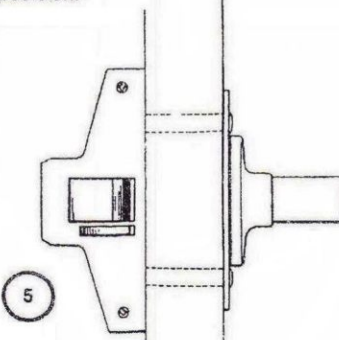

5

Also, if you are using our LHL500, LHL580 or LHL510 with other brands of rim exit devices and if you want to use our deluxe mounting plate, we are in position to supply it in two different ways; one without the holes drilled for the thru mounting sex bolts and our standard mounting plate has the two holes drilled.

The model without the two holes drilled permits you to drill the two thru bolt holes in any position to interface with the position needed to interface with the mounting holes of other rim exit devices.

Also, you may consider the following possibility. When using our LHL500 series locks with the deluxe mounting plate and other brands of exit device, if you do not want to thru bolt it, you can mount it by drilling four screw holes in the corners of the mounting plate and fasten it to the door with fully threaded sheet metal screws.

MOUNT KEYWAY IN KNOB VERTICALLY AS SHOWN

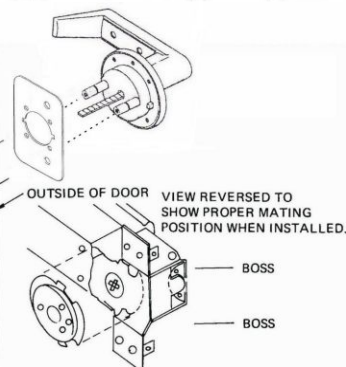
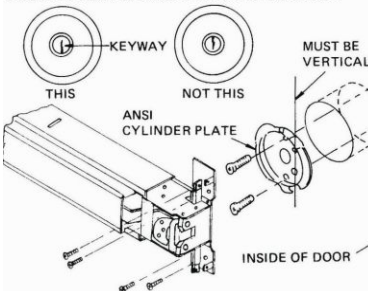

**HOW TO INSTALL HANDING PLATE FOR HANDED EXIT DEVICES
IF YOU ARE USING THIS LOCK WITH A HANDED RIM PANIC DEVICE,
YOU MUST FOLLOW THESE INSTRUCTIONS TO INSTALL THE HANDING PLATE**

Start by removing the Backplate. First remove retaining screws and then pull plate back to expose the internal parts of the lock.

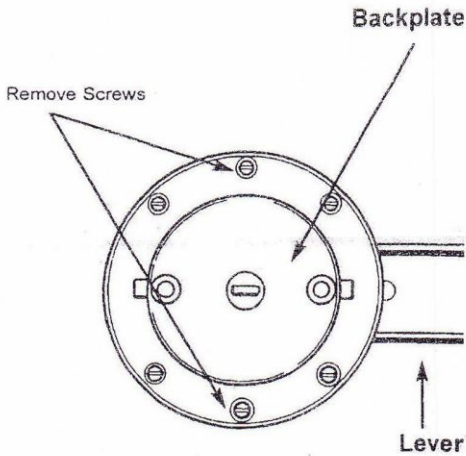

1

After Backplate is removed hold lock in the position shown below and place Handing Plate in its proper housing as indicated in step 3.

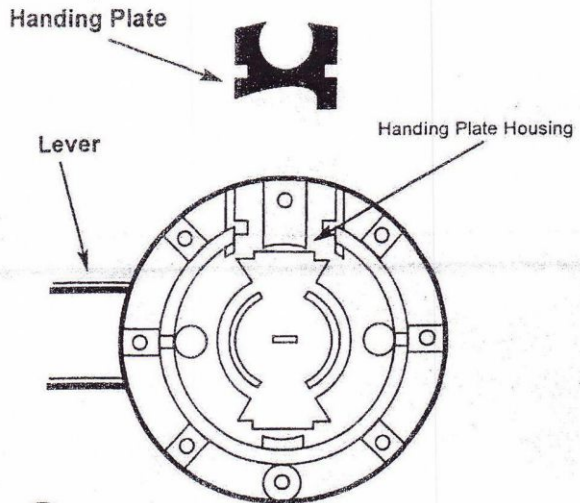

2

NOTE: BEFORE INSTALLING THE LOCK, PLEASE MATCH ROTATION OF LOCK TAIL-PIECE WITH THAT OF EXIT DEVICE ACTUATOR ROTATION. FAILURE TO DO SO WILL RESULT IN BREAKING OF THE TAIL-PIECE OR RENDERING YOUR EXIT DEVICE INOPERATIVE. HOLD LOCK WITH TAIL-PIECE FACING ACTUATOR AND TRY MATCHING ROTATION BEFORE INSTALLING.

A- Insert Handing Plate into position required by the Exit Device you are using.
B- After installing Handing Plate, replace lock Backplate and secure with screws. Now you are ready to install lock onto door.

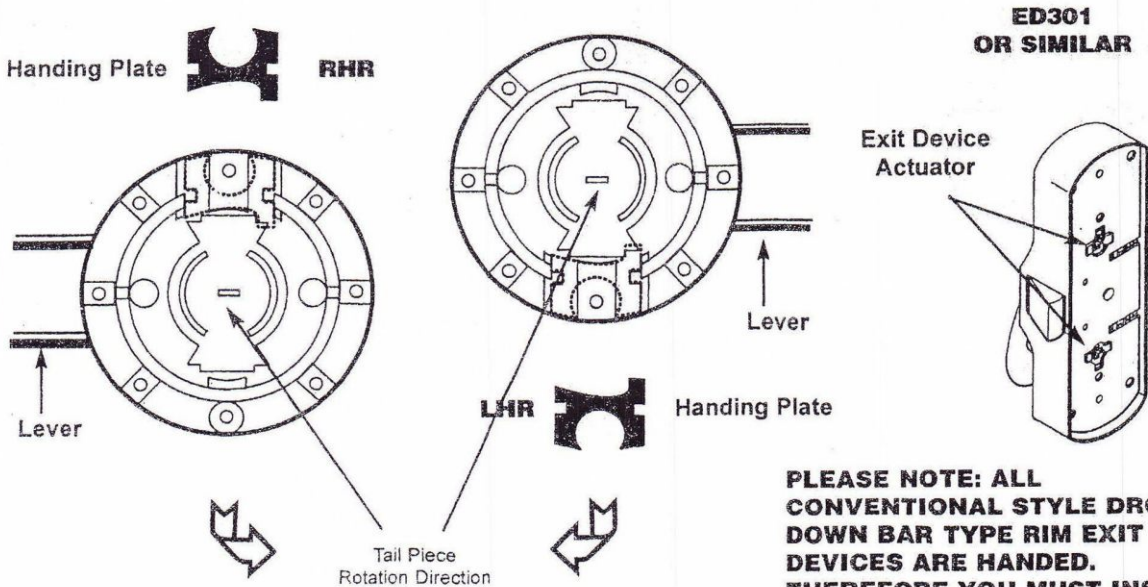

3

PLEASE NOTE: ALL CONVENTIONAL STYLE DROP DOWN BAR TYPE RIM EXIT DEVICES ARE HANDED. THEREFORE YOU MUST INSTALL AND USE OUR "HANDING PLATE"

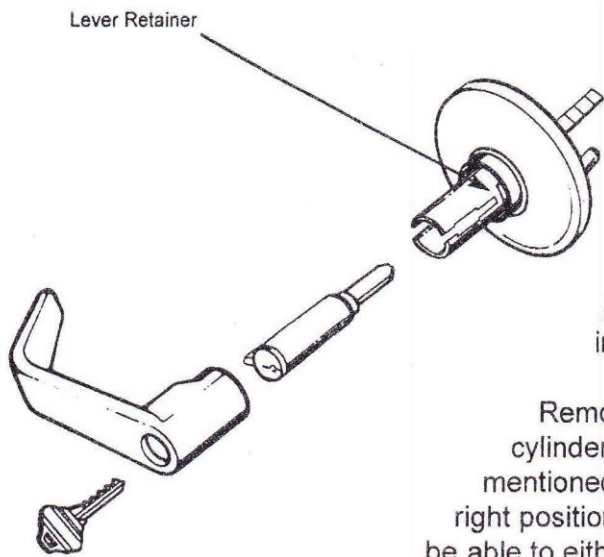

Removing and installing cylinder LHL500:

Turn Key clock-wise 90 dgree, this will lock the lever handle and permit you to push down Lever Retainer pin and disengage lever from lock. Please memorize the cylinder tail piece position, this will aid you in putting the lever back together and speed your installation process.

Remove black plastic cylinder retainer then remove cylinder. After performing service needed, reverse process mentioned above making sure that cylinder tail piece is in the right position. If tail piece is not in proper position, you will not be able to either assemble lock or remove key from cylinder.

Removing and installing cylinder BKL500:

Turn Key clock-wise 90 dgree, this will lock the knob and permit you to push down retainer and disengage knob from lock. Please memorize the cylinder tail piece position, this will aid you in putting the knob back together and speed your installation process.

Remove Cylinder Cap then remove Cylinder. After performing service needed, reverse process mentioned above making sure that cylinder tail piece is in the right position when cylinder was first removed. If tail piece is not in proper position, you will not be able to either assemble lock or remove key from cylinder.

