

- **The Design:** These units feature a solid keypad face with NO cylinder hole.
- **The Advantage:** It is physically impossible to pick, bump, or drill a cylinder because there simply isn't one.
- **The Market:** Perfect for owners who want to eliminate key management entirely. It wipes out the recurring costs of lost keys and re-keying. It offers pure, high-security mechanical code access with zero physical vulnerabilities.

### CONVENIENT INSTALLATION



## FUNCTION DISPLAY DIMENSIONS



Each package includes both a knob and a thumb turn, allowing users to choose based on their preference.

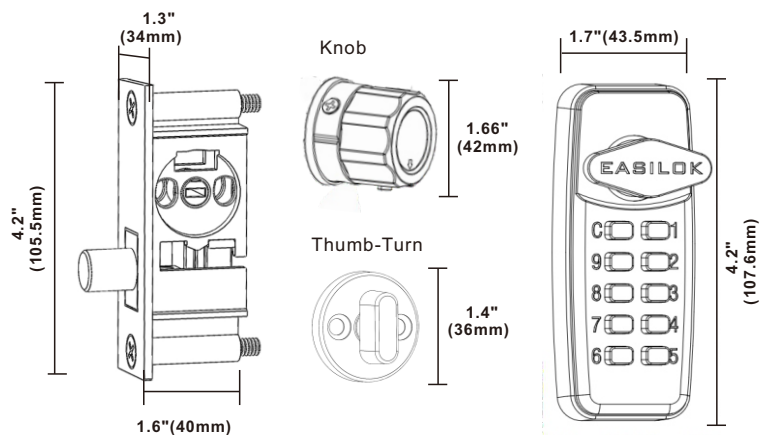

### Specifications:

Product Name: Keyless Keypad Bottom Rail Lock

Model: SK777

Function: Keyless Locking + Keyless Unlocking

Finish: Lacquered

Material: Zinc Alloy + Iron Steel

Manufacture Process: Zinc Alloy Casting + Iron Steel Stamping

Color: Black/Silver

Fit for Door Thickness: 1-3/8" to 1-3/4"

Cylinder: No

Warranty: 3 Years Mechanical Warranty

Installation Instruction: Included

Replacement Model: CRL 777S, FHC R777, and ILCO BRL.

**MAP: \$250**