

Medium Duty Commercial Cylindrical Locks

LDV (Grade 2)

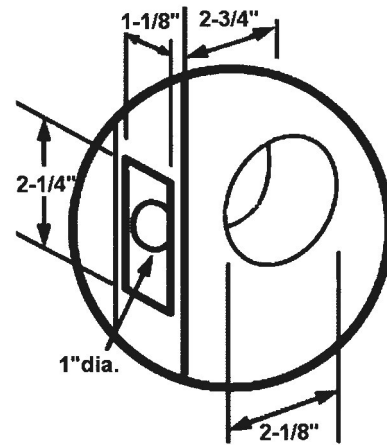

FEATURES:

- Non-handed and reversible
- 2-3/4" backset, 1-1/8" x 2-1/4" faceplate
- PLKASA - 4-7/8" x 1-1/4" ANSI strike
- Schlage "C" 6-pin keyway standard
- Sparta and Saturn lever trim
- Barrier-free and returns within 1/2" from the door face
- Door thickness 1-3/8" - 1-3/4"

Additional backset, springlatch, deadlatch, and accessory options available (see page 13)



CODE COMPLIANCE:

- ANSI A156.2 Grade 2. UL10C and UBC 7.2 for positive pressure
- ANSIA117.1 and ADA for barrier-free accessibility
- C-UBC California Amended Uniform Builders Code - 2001
- NFPA-80 National Fire Protection Assoc. - 1999
- NFPA-101 National Fire Protection - Life Safety 2000

1 YEAR LIMITED WARRANTY

Item	Sparta 26D	Saturn 26D
LDV10	•	•
LDV20	•	•
LDV40	•	•
LDV53	•	•
LDV70	•	•
LDV80	•	•
LDV170	•	•