

Continuous Geared Aluminum Hinges

CH881120HD / CH882240HD – Heavy Duty Full-Mortise

FEATURES:

- Concealed/mortise leaf
- May be used with any door material
- Heavy duty for high frequency 1 3/4" doors or heavy medium frequency doors up to 450 lbs.
- For new construction
- For renovation with new door and/or frames
- No mortising of doors or frame required
- Will cover hinge cut outs in frames
- Flush mount, no inset
- Frame and door leaf alignment ribs for proper hinge location

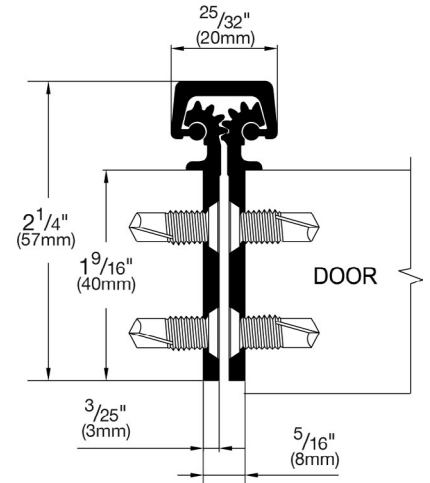

SPECIFICATIONS:

FASTENERS: Self-tapping Screws
Full Mortise Hinges

- All fasteners are No. 12-24 x 1/16" Type C, FHUC
- Heavy duty hinges - 10 required for each leaf

LENGTH OPTIONS: 83" (7'0" opening) & 95" (7'2" - 8'0" opening)

DOOR REINFORCEMENT: None needed. Use 16-gauge channel over 200 lbs.

FRAME REINFORCEMENT: None needed to 200 lbs. Use 16-gauge channel over 200 lbs.

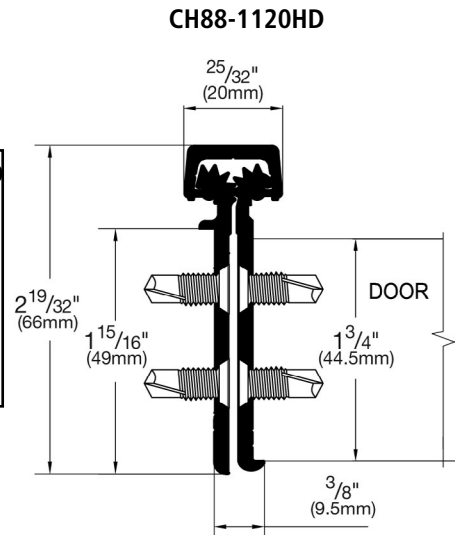

MODEL#	LENGTH	SCREW COUNT DOOR/JAMB	CLEARANCE
CH881120HD	83"	19/19	5/16" (8mm) hinge side plus standard lockside clearance
CH881120HD	95"	19/19	5/16" (8mm) hinge side plus standard lockside clearance
CH882240HD	83"	19/19	5/16" (8mm) hinge side plus standard lockside clearance
CH882240HD	95"	19/19	5/16" (8mm) hinge side plus standard lockside clearance

Available Finishes:
CLR (Clear Anodized Aluminum)
DB (Dark Bronze Anodized Aluminum)
BLK (Black)

LIMITED LIFETIME WARRANTY

Item	Length	CLR	DB	BLK
CH881120HD	83"	•	•	•
	95"	•	•	
CH882240HD	83"	•	•	•
	95"	•	•	

Continuous Geared Aluminum Hinges

CH881570HD / CH882100HD – Heavy Duty Full Surface

FEATURES:

- Full surface
- May be used with any door material
- Heavy duty for high frequency 1-3/4" doors or heavy medium frequency doors up to 450 lbs.
- Replacement for existing doors and frames 7/8" minimum frame 1/16" inset

SPECIFICATIONS:

FASTENERS:

Self-Tapping screws. Full surface hinges

1) Frame Portion

- All fasteners are No. 12-24 x 1/16" type C, FHUC
 - Heavy duty hinges - 10 required for each leaf

2) Door Portion

- Throughbolt 1/4 in. -20 x 1-5/8" PCH
 - Heavy duty hinges - 6 required for each leaf
- Shoulder bolt 1/4 in. -20 x 1" PCH
 - Heavy duty hinges - 6 required
- Pan head self drilling No. 12 x 3/4"
 - Heavy duty hinges - 4 required

LENGTH OPTIONS: 83" (7'0" opening) & 95" (7'2" - 8'0" opening)

DOOR REINFORCEMENT: None needed

FRAME REINFORCEMENT: None needed to 200 lbs. Use 16-gauge channel over 200 lbs.

MODEL#	LENGTH	SCREW COUNT DOOR/JAMB	CLEARANCE
CH881570HD	83"	19/19	1/32" (1mm) minimum recommended for hinge side plus standard lockside clearance
CH881570HD	95"	20/20	
CH882100HD	83"	19/19	1/32" (1mm) minimum recommended for hinge side plus standard lockcase clearance
CH882100HD	95"	20/20	1 5/8" (41mm) minimum frame face required plus 3/16" (5mm) rotational clearance

Available Finishes:

CLR (Clear Anodized Aluminum)

DB (Dark Bronze Anodized Aluminum)

LIMITED LIFETIME WARRANTY

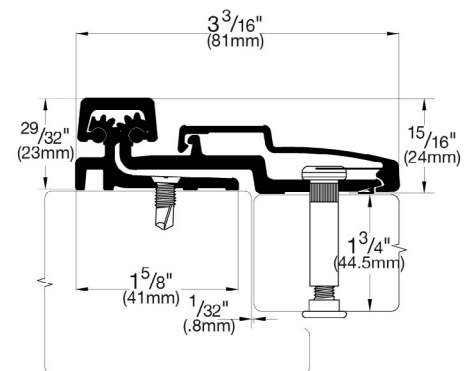
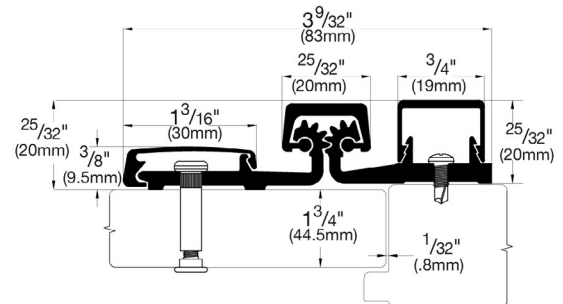

Item	Length	CLR	DB
CH881570HD	83"	•	•
	95"	•	•
CH882100HD	83"	•	•
	95"	•	•