

SPECIFICATIONS

Operating Voltage	12 or 24 Volts AC or DC Auto-sensing
Active Current Draw	50 mA maximum @12VDC 65 mA maximum @24VDC
Idle Current Draw	9 mA maximum @12VDC 17 mA maximum @24VDC
Output Relay Contact Rating	10A@28VDC
Output Contact Arrangement	Single Pole Double Throw
Dimensions	2.875"W x 4.5"L x 1.375"D

MODEL KP-100 ACCESS CONTROL DIGITAL KEYPAD OPERATING INSTRUCTIONS



Model KP-100 is a self-contained digital keypad. This keypad is suitable for residential, industrial, and commercial installations. It is compatible with all electric locking devices.

INSTALLATION

1. Pass the wire harness through the opening in the back box.
2. Mount the back box to the door frame or wall.
3. Make all required wiring connections to the terminal blocks.
4. Place the keypad faceplate on the back box and secure with the screws provided.

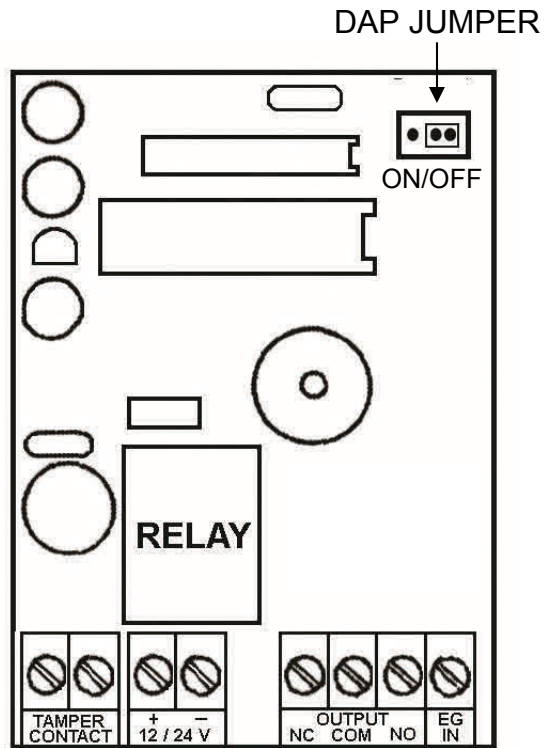

WIRING

Power Input (12-24V AC/DC)	12 or 24 AC or DC. AC power can be connected without observing polarity requirement. Connect DC power with polarity as indicated.
Output Relay	SPDT dry contacts. Output can be programmed for latching or momentary operation.
Egress Input (EG IN)	A normally-open request to exit station can be connected to this terminal and ground (-). Connecting the terminal to ground will operate the output in the same manner as a valid user code.
Tamper Contact	Normally-closed output pair activated by the tamper switch if the keypad faceplate is removed from the back box.

BASIC WIRING DIAGRAM

Use N/C contact for magnetic locks and fail-safe electric strikes.

Use N/O contact for fail-secure electric strikes.

The 1N4004 Diode must be used for DC powered electric strike applications.

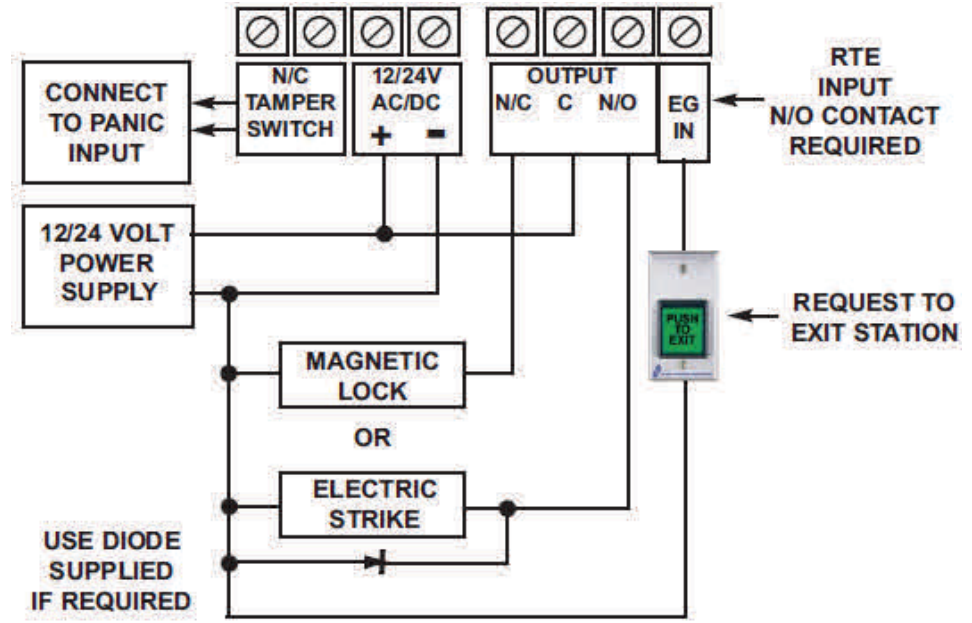

TAMPER SWITCH

The Tamper Switch is Normally-closed when the keypad face plate is securely attached to the back box. Connect these terminals to an alarm panel if desired.

CODES

It is recommended that the *Installer Code* and *User Codes* be noted here for reference.

Installer Code	
User Code _____	
User Code _____	
User Code _____	
User Code _____	
User Code _____	
User Code _____	
User Code _____	
User Code _____	
User Code _____	
User Code _____	
User Code _____	

KEYPAD LOCKOUT

The keypad can be temporarily disabled to prevent unauthorized access by entering a user specified 4 to 8 digit *Lockout Code*. The red LED will light when the keypad is in Lockout Mode. The keypad can be taken out of Lockout Mode by entering the *Lockout Code* again.

1. Put the keypad in *Program Mode* by entering the *Installer Code* followed by the “*”. The keypad will beep twice and the yellow LED will be on and not blinking.
2. Enter “**5 1 #**”
3. Enter “**2 1 (Lockout Code) #**”.
For example, if you wish to assign a *Lockout Code* of “6 7 8 9”, you would enter “**2 1 6 7 8 9 #**”.
3. Enter “*” to exit Program Mode. The red LED will illuminate.

DIRECT ACCESS TO PROGRAMMING (DAP)

If the *Installer Code* is forgotten, the *Direct Access to Programming (DAP)* utility can be used to put the keypad in *Programming Mode*.

1. Disconnect the power supply from the keypad.
2. Move the DAP jumper from the OFF to the ON position.
3. Reconnect the power supply to the keypad (keypad will start beeping).
4. Move the DAP jumper from the ON to the OFF position (keypad will stop beeping and the yellow LED will be on and not blinking. The keypad is now in *Programming Mode*).
5. A new *Installer Code* must now be entered.
6. Enter “**0 (4 to 8 digit new installer code) #**”. For example, if you wish to change the *Installer Code* to 1 2 3 4 you would enter “**0 1 2 3 4 #**”.
7. The keypad will beep twice indicating that the new *Installer Code* has been accepted.
8. Enter “*” to exit *Program Mode*. The yellow LED will begin blinking.

LED AND TONE INDICATORS

The Green LED is on while Output Relay is activated.

The Red LED is on while keypad is in Lockout Mode.

The Yellow LED is described in the table below -

Yellow LED	Keypad Status	Tone Indicator
On	Programming Mode	None
1 Blink	Successful Key Press	1 Beep
2 Blinks	Successful Code Entry	2 Beeps
5 Blinks	Error in Code Entry	5 Beeps
Continuous Blinking	Standby Mode	None
Continuous Blinking	DAP Jumper not replaced	Continuous Tone

KEYPAD INITIATION

Keypad initiation must be done at the initial turn-on of the keypad.

1. Connect power to the keypad.
2. Put the keypad in *Program Mode* by entering “**0 0 0 0 ***”. The keypad will beep twice and the yellow LED will be on and not blinking.
3. Enter “**8 9 0 1 #**”.
4. The keypad will beep twice and the keypad initiation is complete.
5. Enter “*” to exit Program Mode. The yellow LED will begin blinking.

ENTERING A NEW INSTALLER CODE

It is strongly recommended that the *Installer Code* be changed from the default “**0 0 0 0**”. If the *Installer Code* is not known, please refer to the section on *Direct Access to Programming*.

1. Put the keypad in *Program Mode* by entering “**0 0 0 0 ***” or the current installer code. The keypad will beep twice and the yellow LED will be on and not blinking.
2. Enter “**0 (4 to 8 digit new installer code) #**”. For example, to change the *Installer Code* to 1 2 3 4 you would enter “**0 1 2 3 4 #**”.
3. The keypad will beep twice indicating that the new *Installer Code* has been accepted.
4. Enter “*” to exit Program Mode. The yellow LED will begin blinking.

PROGRAMMING MODE

It is necessary to put the keypad in *Programming Mode* in order to access all keypad configuration settings.

1. Put the keypad in *Program Mode* by entering the *Installer Code* followed by the “*”. The keypad will beep twice and the yellow LED will be on and not blinking.
2. Enter “*” to exit Program Mode. The yellow LED will begin blinking.

PROGRAMMING USER CODES

User Codes are 4 to 8 digits long and must not be the same as the *Installer Code*.

The keypad can store up to 100 *User Codes*.

Each *User Code* has a *Code Number*. *Code Numbers* are two digits ranging from “**00**” to “**99**”.

1. Put the keypad in *Program Mode* by entering the *Installer Code* followed by the “*”. The keypad will beep twice and the yellow LED will be on and not blinking.
2. Enter “**(1) (Code Number) (User Code) #**”.
For example, if you wish to assign a *User Code* of “6 7 8 9” to *Code Number* “01”, you would enter “**1 0 1 6 7 8 9 #**”.
3. Enter “*” to exit Program Mode. The yellow LED will begin blinking.

OPERATION

Enter a valid *User Code* to activate the Output Relay. The keypad must be in standby mode (yellow LED blinking).

1. Enter “**(User Code) #**”.

For example, if the *User Code* is “1234” you would enter “**1 2 3 4 #**”.

DELETING USER CODES

1. Put the keypad in *Program Mode* by entering the *Installer Code* followed by the “*”. The keypad will beep twice and the yellow LED will be on and not blinking.

2. Enter “**(1) (Code Number) #**”.

For example, if you wish to delete the *User Code* in *Code Number* “02” you would enter “**1 0 2 #**”.

3. Enter “*” to exit Program Mode. The yellow LED will begin blinking.

To delete all *User Codes* enter “**8 9 0 1 #**”.

MOMENTARY OR LATCHING OUTPUT MODES

The Outputs Relay can be programmed for either momentary or latching operation. Momentary operation time can be set for between 1 and 999 seconds. The factory default momentary operation time is 2 seconds.

1. Put the keypad in *Program Mode* by entering the *Installer Code* followed by the “*”. The keypad will beep twice and the yellow LED will be on and not blinking.

2. *Momentary Mode* -

Enter “**4 0 (output active time 1-999) #**”

Latching Mode -

Enter “**4 1 #**”

3. Enter “*” to exit Program Mode. The yellow LED will begin blinking.

KEYPAD SILENT MODE

The keypad beeper can be silenced.

1. Put the keypad in *Program Mode* by entering the *Installer Code* followed by the “*”. The keypad will beep twice and the yellow LED will be on and not blinking.

2. Enter “**8 3 0 #**”.

3. Enter “*” to exit Program Mode. The yellow LED will begin blinking.

To return the keypad to audible mode -

1. Put the keypad in *Program Mode* by entering the *Installer Code* followed by the “*”. The keypad will beep twice and the yellow LED will be on and not blinking.

2. Enter “**8 3 1 #**”.

3. Enter “*” to exit Program Mode. The yellow LED will begin blinking.

AUTO OR MANUAL CODE ENTRY MODE

When the keypad is programmed for *Auto Entry Mode* it is not necessary to terminate *User Codes* with the “#” during operation. However, in *Auto Entry Mode* the *User Code* must be the same length (4 to 8 digits) as the *Installer Code*.

To put the keypad in *Auto Entry Mode* -

1. Put the keypad in *Program Mode* by entering the *Installer Code* followed by the “*”. The keypad will beep twice and the yellow LED will be on and not blinking.

2. Enter “**8 2 1 #**”.

3. Enter “*” to exit Program Mode. The yellow LED will begin blinking.

To return the keypad to *Manual Entry Mode* -

1. Put the keypad in *Program Mode* by entering the *Installer Code* followed by the “*”. The keypad will beep twice and the yellow LED will be on and not blinking.

2. Enter “**8 2 0 #**”.

3. Enter “*” to exit *Program Mode*. The yellow LED will begin blinking.

OUTPUT ANNUNCIATOR

The keypad can be programmed to notify the user when the Output Relay is energized or the egress button has been pressed.

To put the keypad in *Output Annunciator Mode* -

1. Put the keypad in *Program Mode* by entering the *Installer Code* followed by the “*”. The keypad will beep twice and the yellow LED will be on and not blinking.

2. Enter “**8 1 1 #**”.

3. Enter “*” to exit Program Mode. The yellow LED will begin blinking.

To take the keypad out of *Output Annunciator Mode* -

1. Put the keypad in *Program Mode* by entering the *Installer Code* followed by the “*”. The keypad will beep twice and the yellow LED will be on and not blinking.

2. Enter “**8 1 0 #**”.

3. Enter “*” to exit *Program Mode*. The yellow LED will begin blinking.